

ffi Corporation / Farm Fans

Silver King Series Inline Centrifugal Fan **Operators Manual**

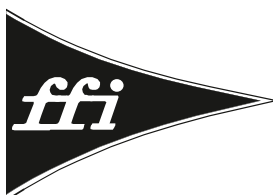

CONTENTS	
Safety Precautions	2
Warranty	2
Installation	3
Dimensions	4
Operation	5
Service	6
Wiring Diagrams	7
Safety Decals	9



Models:
CIL18
CIL24
CIL28

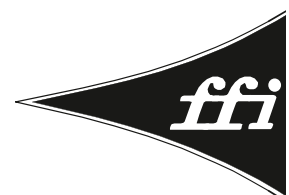

SAFETY PRECAUTIONS

USE CAUTION IN THE OPERATION OF THIS EQUIPMENT

The design and manufacture of this system is directed toward operator safety. However, the very nature of any system using high voltage electrical equipment and rotation parts presents hazards to personnel which cannot be completely safeguarded against without interfering with efficient operation and reasonable access to components.

Use extreme caution when working around rotating parts which may start without warning when the system is operating on "Automatic" control.

Continued safe dependable operation of equipment relies, to a great degree, upon the operator. For a safe and dependable system, follow the recommendations within this manual, make it a practice to regularly inspect the operation of the system for any unsafe conditions or developing problems.

TAKE SPECIAL NOTE OF THE OPERATING PRECAUTIONS BELOW BEFORE ATTEMPTING TO OPERATE THE SYSTEM.



CAUTION: Guards, access doors and covers must be securely fastened before operating this equipment.

A CAREFUL OPERATOR IS THE BEST INSURANCE AGAINST AN ACCIDENT.



Look for this symbol to point out important safety precautions. It means ATTENTION!

1. Read and understand the operation manual before attempting to operate the unit.
2. Keep ALL guards, access doors, covers, safety decals and safety devices in place and securely fas-

tened. NEVER operate system while guards are removed.

3. Keep all untrained personnel away from system components and control panel at all times.
4. NEVER attempt to operate the unit by jumping or otherwise bypassing any safety devices.
5. Always open the main power supply disconnect switch and lock it in the open position with a padlock when performing any service or maintenance work on the fan unit or control box.
6. Lock out power before removing guards, access doors, and covers.
7. Keep hands, feet and clothing away from all rotating parts.
8. Electrical repairs should be performed by trained qualified personnel only. Failure to follow safe electrical procedures can result in serious injury.
9. If it should become necessary to perform checks on system components or high voltage tests with "live" circuits, be extremely careful and follow all established safety practices.

WARRANTY

Farm Fans warrants its products to be free of defects in material and workmanship. The only obligation of the manufacturer is to repair or replace products which have been submitted and found to be defective within 24 months after installation. If so found defective, the products will be repaired or replaced without charge, this constituting and entirely fulfilling the warranty obligation. Farm Fans assumes no liability for expenses incurred without written authorization; in no event shall its liability include special or consequential damages or exceed the selling price of the product.

This warranty does not cover products or parts which have been damaged by negligent use, misuse, alteration or accident. Some components supplied by man-

ufacturers are warranted separately by those suppliers. This warranty is exclusive and in lieu of all other warranties, expressed or implied. Farm Fans reserves the right to make design or specification changes at any time without any contingent obligation to purchasers of products already sold.

All instructions, with the exception of those concerning safety, shall be construed as recommendations only; because of the many variable conditions in actual installation, Farm Fans assumes no liability for results arising from the use of such recommendations.

INSTALLATION

FOUNDATION

For proper operation of your ffi fan, the unit is to be mounted on a level pad. The fan should not be anchored to the pad but should be allowed to “float” on the pad. The fan pad should be at the same elevation as the floor of the bin or building.

FAN INSTALLATION

1. See dimension illustration for the physical size of the fan. Use the dimensions shown to determine the position of the fan when installed.
2. Rotate the fan wheel to be sure it revolves freely and does not contact the housing.
3. Check all fasteners on the fan to make sure they are tight (fasteners may loosen during shipping). If any loose fasteners are found, check for proper clearance and retighten.
4. Check all electrical connections that may have loosened during shipping.
5. Make certain that all joints and seams around the lower part of the bin are well sealed to prevent air leakage from the air space under the perforated drying floor. The connecting air duct must be reasonably airtight. Air leakage wastes fan efficiency.
6. The connecting air duct or “transition duct” and connector should be all metal construction, with a gradual angle to the rectangular opening through the bin wall.
7. Avoid abrupt angles or any type of connecting air duct that would restrict airflow. The cross-sectional area of the connecting duct should gradually increase to about 1.5 times the fan area where it enters the air chamber through the bin wall.
8. Keep the air entrance as clear as possible from obstruction by floor supports.
9. **Adequate exhaust air openings in the roof are required to prevent any additional back pressure (2 to 3 times fan outlet cross-sectional area).**

ELECTRICAL INSTALLATION

1. The electrical installation must be performed by a certified electrician, in accordance with the appropriate national and local electrical codes. Any violation of electrical wiring codes could jeopardize the ffi warranty.
2. ffi Corporation recommends contacting your local power company to advise them of the additional load to be placed on their line. Only the power company representative can ensure that their system is sized properly to provide adequate service to your facility and new equipment.
3. Each fan motor must be supplied with an independent power circuit, equipped with a fused disconnect switch. Locate this switch near the unit, as the power should be

shut off before opening the control box cover, or performing any service on the unit. **NOTE:** The fused disconnect is provided by the owner and **MUST BE CORRECTLY SIZED AND CONNECTED TO ALLOW PROPER MOTOR OPERATION.**

UNITS WITHOUT CONTROLS - It is the customer's responsibility to provide a fused disconnect and motor overload protection. The disconnect and overload device must be sized and connected correctly to allow proper motor operation. Failure to provide these components could cause severe motor damage and void the manufactures warranty.

4. Be sure that the disconnect and the fan are well grounded.
5. The following wires must be supplied to each fan. Units without control transformers require a separate neutral and earth ground connection.

1PH 230VL1, L2, N, G
3PH 230VL1, L2, L3, N, G
3PH 230V with optional transformer kitL1, L2, L3, G
3PH 460VL1, L2, L3, G
6. Use electrical conductors of adequate size. Undersized wire can lead to voltage drop and cause motor overheating and shortened life. Therefore, it is necessary to know the distance from the unit to available transformer and the horsepower of your fan unit. These two factors will determine the size of wire needed for efficient operation. The full load current is listed in Tables 1 and 2. The full load current is also stamped on the motor nameplate.
7. The starter controls require 115VAC power to operate. On 230V 3PH units, this power is supplied by L1 to neutral.

WARNING! The voltage between L1 and N must be 115VAC. Any other voltage may cause severe damage to equipment.

Check this voltage before starting unit. If voltage is not within 105-125VAC, check for proper voltage on L2 or L3 and move to appropriate leg. If voltage is not acceptable, install a 0.25 KVA step-down transformer kit (part no. TRANS-230). (**Note:** Grounded B and some open delta power supplies will require this transformer kit.)

INSTALLATION CHECK

When the fan is completely installed, the unit will need to be checked for proper rotation. Provide power to the fan controls and start the fan momentarily. Make sure that the fan wheel rotation is in the direction that the decal on the fan housing illustrates. If the decal is missing, note that the wheel should operate clockwise when viewed through the inlet guard. If the wheel is rotating the wrong direction, have your electrician correct the wiring.

INLINE CENTRIFUGAL FAN DIMENSIONS

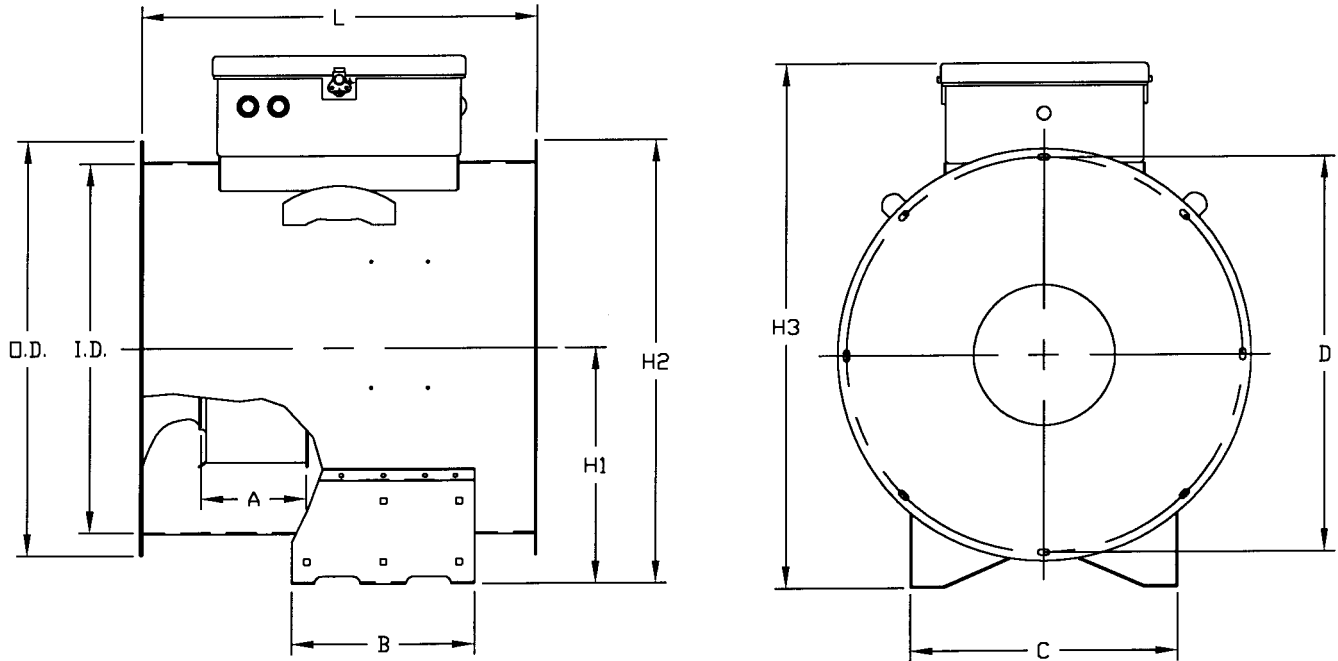

FAN MODEL	I.D.	O.D.	FAN L LENGTH	H1 FAN HEIGHT	H2 FAN HEIGHT	H3 FAN HEIGHT
AV18	18.25	21.00	23	12.875	23.375	29.00
AV24	24.25	27.25	26	15.50	29.125	34.625
AV28	28.25	31.25	28	18.25	34.125	39.375

FAN MODEL	DIM "A"
AV18-1	3.75
AV18-4	6.25
AV24-5	6.875
AV24-10	6.875
AV28-15	5.95

FAN MODEL	FAN BASE		D BOLT CENTER DIA.	GA.	BOLT SIZE
	B	C			
AV18	10.50	12.875	19.75	12	5/16
AV24	12.00	17.50	26.00	12	5/16
AV28	14.00	20.00	29.75	12	5/16

cildim.tif

TABLE 1 ELECTRICAL SERVICE - SINGLE PHASE						
MOTOR HP	115V Single Phase			230V Single Phase		
	Full Load Amps	Overload Relay	Heater Element	Full Load Amps	Overload Relay / Part Number	Heater Element / Part Number
1.5-3.0	--	--	--	14	27A / 056-1062-1	C16.3 / 056-1143-9
3-4.5	--	--	--	20	27A / 056-1062-1	C22.8 / 056-1166-0
5-7	--	--	--	35	45A / 056-1046-4	C30.3 / 056-1142-1
7.5-10	--	--	--	42	45A / 056-1046-4	C33.0 / 056-1153-8
10-15	--	--	--	55	90A / 056-1083-7	F56.7 / 056-1203-1

TABLE 2 ELECTRICAL SERVICE - THREE PHASE

MOTOR HP	230V Three Phase			460V Three Phase		
	Full Load Amps	Overload Relay / Part Number	Overload Setting	Full Load Amps	Overload Relay / Part Number	Overload Setting
1.5-3.0	8.5	7-10A / 056-2022-4	8.5	4	4-6A / 056-1968-9	4
3-4.5	13	12-18A / 056-1944-0	13	6	5.5-8A / 056-1949-9	6
5-7	15	12-18A / 056-1944-0	16	7.5	7-10A / 056-2022-4	7.5
7.5-10	24	17-25A / 056-1943-2	25	12	9-13A / 056-1971-3	12
10-15	30	23-32A / 056-2079-4	32	15	12-18A / 056-1944-0	15

OPERATION

After initial installation and also prior to using the unit each season, check the operation to ensure proper functioning, adjustment, and reliability.

FAN OPERATION

1. Make certain that unit is properly installed and connected, as described within the installation instructions. All air passage joints and seams must be well-sealed.
2. With main power supply turned OFF, rotate the wheel by hand to make certain it turns freely without contacting the housing or inlet cone.
3. Open roof doors to allow airflow at all times when fan is operating.



CAUTION: Fan pressures can overload bin roof or walls causing structural damage or collapse. Bin must be adequately ventilated and fans and screens free of obstructions. Do not run fans if icing can occur on screens.

4. Turn ON main power disconnect switch.



CAUTION: Make certain all guards and covers are securely in place.

5. Press the fan START button and check the following:

A. Check direction of wheel rotation. THIS IS A VERY IMPORTANT CHECK ON INITIAL START-UP OF 3-PHASE MODELS. The wheel must rotate clockwise when viewed through the inlet guard.

NOTE: 3-Phase motors may be reversed by interchanging any two power leads.

B. Check to make sure the wheel comes to full operating speed in less than 10 seconds. If there is any doubt as to proper operation, check the current draw of the motor. The motor amperage should not exceed the maximum full load amps listed within Tables 1 and 2 or motor nameplate.

FAN SHUT-DOWN

1. Press the fan STOP button on units equipped with motor controls.
2. Shut off electrical power at main and at disconnect.
3. Close the roof openings and cover fan inlet to prevent harmful back-draft air currents from passing through the grain and to avoid grain infestation from rodents and insects.

CENTRIFUGAL INLINE FANS STATIC PRESSURE (INCHES) & AIR FLOW RATINGS (CFM)

Fan Model	PRESSURE IN INCHES											
	0.00	1.00	2.00	3.00	4.00	5.00	6.00	7.00	8.00	9.00	10.00	11.00
AIR FLOW IN CFM												
FFI CIL18-1	2700	2500	2300	2070	1900	1550	-	-	-	-	-	-
FFI CIL18-4	4250	3950	3680	3360	3060	2625	-	-	-	-	-	-
FFI CIL24-5	6360	6040	5720	5400	4980	4550	4020	3500	-	-	-	-
FFI CIL24-10	7260	6890	6360	5900	5600	5200	4770	4450	3180	-	-	-
FFI CIL28-15	10190	9800	9400	9100	8600	8200	7600	7250	6550	5680	5000	3600

Airflow ratings were determined in accordance with AMCA test code Standard 210.

FAN WHEEL REMOVAL & INSTALLATION

The fan wheel is secured to the motor shaft by the use of a taper-lock bushing, motor shaft key, and cap-screws. The size, quantity, and torque of capscrews required will depend on the model of the fan.



CAUTION: Although the taper-lock method of retaining the wheel onto the motor shaft is very simple and obvious, it is essential that the following points be read carefully and fully understood, as improper installation can result in serious or fatal injury caused by a loose, fast flying wheel.

THREADED BUSHING HOLES: The threaded holes within the bushing are provided for disassembly purposes only. Do not attempt to use these holes for reassembly, as they will not allow the parts to become locked onto the shaft, thereby causing an extremely hazardous operating condition.

CLEARANCE HOLES: When reassembling parts, the capscrews must be installed through the **UNTAPPED CLEARANCE HOLES** to cause the wheel to be pulled forward onto the tapered bushing, thus locking the parts securely onto the motor shaft. Refer to text for assembly details.

REMOVAL

1. LOCK-OUT THE MAIN POWER SUPPLY and remove the fan guard and inlet cone.
2. Remove the three capscrews from the clearance holes in taper-lock bushing. Inspect for thread damage and set aside for later reinstallation (do not use these bolts for step 3, bushing removal).
3. Install two Grade 5 (or better) capscrews into the **THREADED HOLES** in the bushing and turn them in by hand until they bottom against the front surface of the wheel. These capscrews should not be used for reassembly, as some thread distortion could occur during the removal operation. Grade 5 screws are marked with three 120° spokes on the head and are more durable than low strength unmarked bolts.

NOTE: DO NOT ATTEMPT TO USE LOW STRENGTH (UNMARKED) BOLTS TO REMOVE THE BUSHING, AS THE BOLTS MAY BREAK OFF.

4. Block wheel to prevent it from turning, and **GRADUALLY TURN IN THE CAPSCREWS** (up to 1/4 turn at time), until the wheel breaks loose from the bushing and motor shaft. Carefully remove bushing and wheel. With the wheel free from the bushing, a wheel puller can be used to pull the bushing off of motor shaft, if required. Reattach bushing onto wheel to prevent the loss of parts and also to maintain the original alignment of bushing to wheel. Inspect wheel and bushing at this time, looking for any cracks, thread or bolt damage, warpage, etc. Consult your dealer or the factory for any questions concerning damage.

INSTALLATION

1. Carefully clean motor shaft, key, bushing and bore of wheel. **MAKE SURE MAIN POWER IS LOCKED OUT**, and that shaft and key are completely free of rust and burrs. Do NOT lubricate the bushing or capscrews. **CHECK AND MAKE SURE ALL MOTOR MOUNT BOLTS ARE PROPERLY TIGHTENED.**

Before installing the wheel, check the following: (1) All foreign material should be removed from the wheel. (2) Carefully inspect the wheel weldment and hub casting for damage, cracks, or other defects. Contact the factory if there is any question regarding the structural integrity of the wheel.

2. Slide wheel over motor shaft and locate it against the motor.
3. Align the keyway in the bushing with the key and **SLIDE** bushing onto motor shaft. Do not attempt to drive the bushing onto the shaft, as it may damage the motor bearings.
4. Rotate the bushing and wheel so their key slots are in line and loosely attach the wheel to the bushing. **MAKE SURE THE CAPSCREWS ARE INSERTED INTO THE UNTHREADED CLEARANCE HOLES IN THE BUSHING.** Refer to previous CAUTION note. Locate the bushing so it is approximately flush with the end of motor shaft.

Make certain that the proper capscrews are used for reassembly and no damage has occurred to these screws during disassembly! Use only the special type bolts supplied with the original wheel.

5. Install inlet cone, checking clearance between fan wheel and inlet cone. Shift the location of inlet cone as required to center it in relation to the fan wheel, providing equal clearance completely around the fan wheel. Tighten inlet cone bolts.
6. Slide the wheel forward onto the taper-lock bushing and turn the capscrews in by hand as far as possible.

NOTE: The bushing must be located far enough forward so the distance from the inside of the backplate of the wheel weldment to the closest edge of the inlet cone is equal to the dimension shown as 'A' in the Fan Dimension Chart. Add approximately 1/8" to this dimension to allow the wheel to be pulled toward the inlet during tightening.

7. Use an **INCH-POUNDS** torque wrench and **GRADUALLY TIGHTEN** the three capscrews (1/4 turn at a time) until the taper bushing becomes fully seated. Refer to the following chart for recommended capscrew tightening torques. **DO NOT EXCESSIVELY OVERTIGHTEN THE BUSHING.**

Browning Taper-Lock Bushing Bolt Tightening Torques

Bushing Size	Hex Bolt Size	Torque (Inch-Lbs.)
P	5/16-18x1-1/4	192

CAUTION: Do not attempt to pull the flange of the bushing flush with the wheel hub. A clearance of from 1/8" to 1/4" must be maintained between bushing flange and wheel hub surface.

- Turn wheel by hand and check it for freedom of rotation and uniform clearance around inlet cone before re-installing the fan guard.

FAN MOTOR REMOVAL & INSTALLATION

In the event of motor failure, remove the motor, as described, and take it to the nearest Authorized Service Station. AUTHORIZED SERVICE STATIONS ARE THE ONLY PLACES THAT CAN PROVIDE MOTOR WARRANTY. Motor service and repair at other places will be at owner's expense.

If service station determines motor failure to be caused by faulty material or workmanship, repair will be under warranty when within the warranty period. Motor failure because of external causes will result in a charge to the owner for repair.

- Make certain power is shut off and locked out, then remove fan guard, inlet cone, and wheel as outlined earlier.

- Open motor junction box cover and disconnect the motor lead wires from within the box.

NOTE: Tag, or otherwise identify wires for ease of reassembly.

- Remove motor mount bolts. If there are any shims between the motor and its base, note their locations so they can be properly installed during reassembly.
- Disconnect the motor end of the motor conduit, if required, then carefully pull conduit and wires through hole in the motor junction box. Remove motor. If motor requires service, take it to an Authorized Service Station.
- To reinstall motor, slide onto motor mount and replace shims (if required) between motor and mount. Reinstall motor mount bolts and washers, and fully tighten them at this time.

Reinstall conduit and wires and carefully remake all electrical wiring connections.

NOTE: Make sure to install and tighten the wheel in accordance with earlier instructions.

WIRING DIAGRAMS

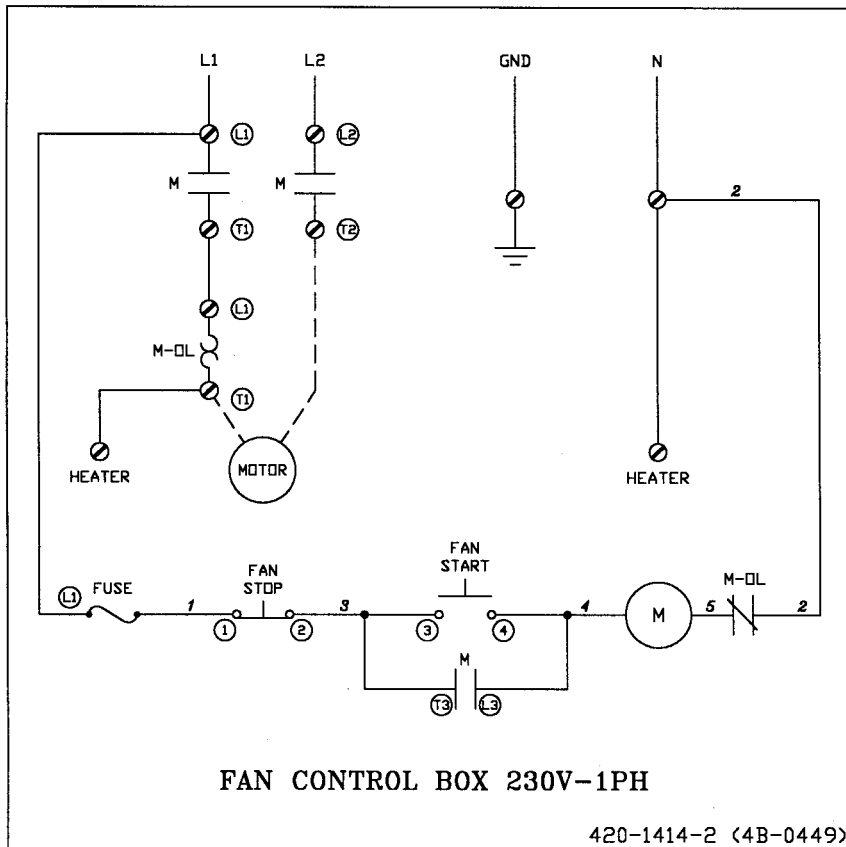

Fig. 1 - Fan control box wiring diagram, 230V 1 phase

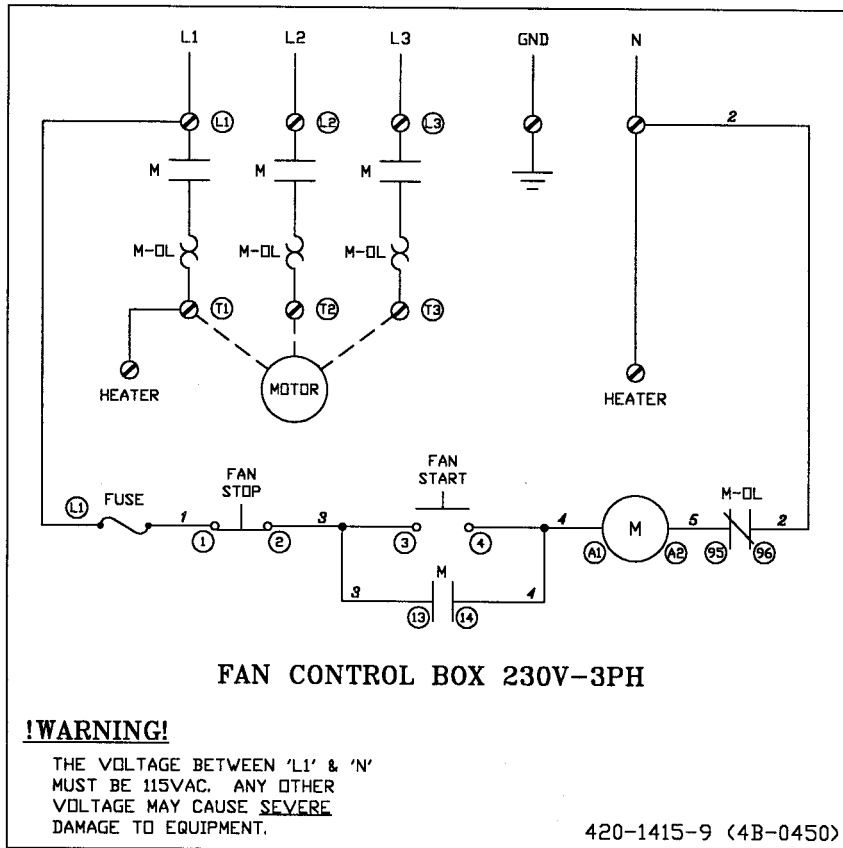

Fig. 2 - Fan control box wiring diagram, 230V 3 phase

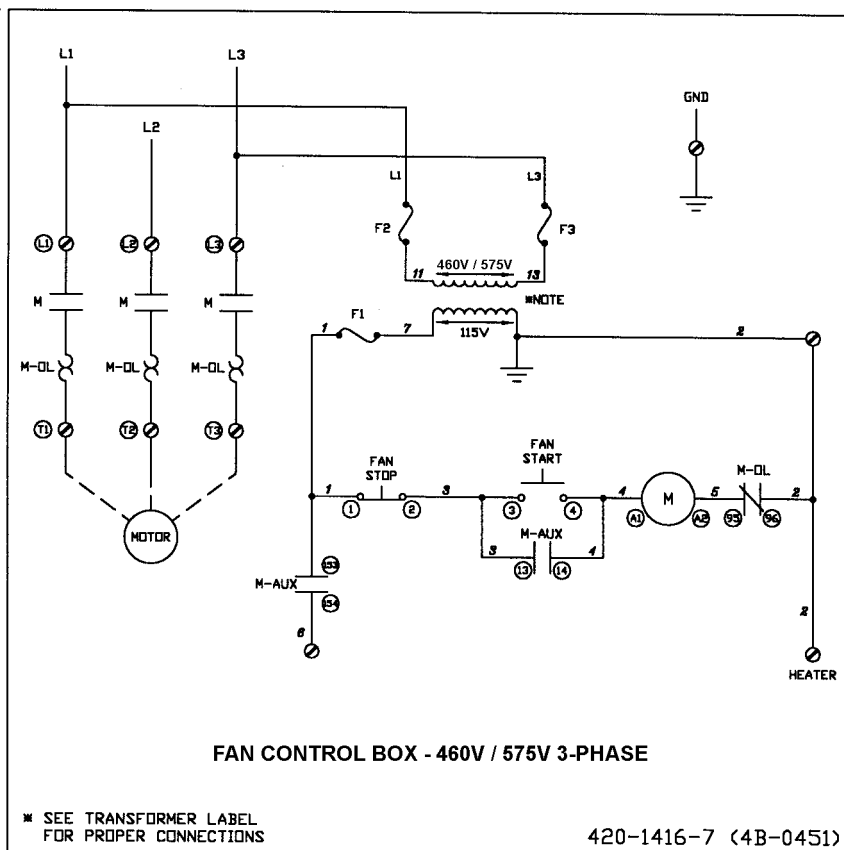

Fig. 3 - Fan control box wiring diagram, 460V / 575V 3 phase

SAFETY DECALS

Safety decals should be read and understood by all people in the grain handling area.

If a decal is damaged or missing, contact:

ffi Corporation
5900 Elmwood Ave.
Indianapolis, IN 46203

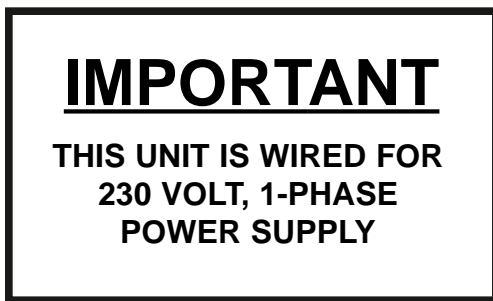

(Typical for 230V 1 phase models)



Copyright © 1998 ffi Corporation
5900 Elmwood Ave.
Indianapolis, Indiana 46203

7-29-98

