

Scattergrain Grain Spreader Installation & Operating Instructions

MODEL # FFD-200-1
MODEL # FFD-200-3

Owner's Manual

MANUAL # PNEG-267



THE GSI GROUP



SUPER SPREAD OPERATING INSTRUCTIONS

TABLE OF CONTENTS

Warranty	4
Safety Guidelines	5
Roof Warning, Operation & Safety	6
Safety Alert Decals	7
Hardware List For FFD-200-1 & FFD-200-3	8
Super Spread Parts List	10
Super Spread Parts Assembly	11
Super Spread Installation	12
Single Phase-Dual Voltage Wiring Diagram	13
Three Phase-Dual Voltage Wiring Diagram	13
Super Spread Operating Instructions	15
Adjustment For Bin Fill	16
Maintenance	17
Troubleshooting Guide	18
Correct Spreading Pattern	18

WARRANTY

THE GSI GROUP, INC. ("GSI") WARRANTS ALL PRODUCTS MANUFACTURED BY GSI TO BE FREE OF DEFECTS IN MATERIAL AND WORKMANSHIP UNDER NORMAL USAGE AND CONDITIONS FOR A PERIOD OF 12 MONTHS AFTER RETAIL SALE TO THE ORIGINAL END USER OF SUCH PRODUCTS. GSI'S ONLY OBLIGATION IS, AND PURCHASER'S SOLE REMEDY SHALL BE FOR GSI, TO REPAIR OR REPLACE, AT GSI'S OPTION AND EXPENSE, PRODUCTS THAT, IN GSI'S SOLE JUDGMENT, CONTAIN A MATERIAL DEFECT DUE TO MATERIALS OR WORKMANSHIP. ALL DELIVERY AND SHIPMENT CHARGES TO AND FROM GSI'S FACTORY WILL BE PURCHASER'S RESPONSIBILITY. EXPENSES INCURRED BY OR ON BEHALF OF THE PURCHASER WITHOUT PRIOR WRITTEN AUTHORIZATION FROM AN AUTHORIZED EMPLOYEE OF GSI SHALL BE THE SOLE RESPONSIBILITY OF THE PURCHASER.

EXCEPT FOR THE ABOVE STATED EXPRESS LIMITED WARRANTIES, GSI MAKES NO WARRANTY OF ANY KIND, EXPRESSED OR IMPLIED, INCLUDING, WITHOUT LIMITATION, WARRANTIES OF MERCHANTABILITY OR FITNESS FOR A PARTICULAR PURPOSE OR USE IN CONNECTION WITH (i) PRODUCT MANUFACTURED OR SOLD BY GSI OR (ii) ANY ADVICE, INSTRUCTION, RECOMMENDATION OR SUGGESTION PROVIDED BY AN AGENT, REPRESENTATIVE OR EMPLOYEE OF GSI REGARDING OR RELATED TO THE CONFIGURATION, INSTALLATION, LAYOUT, SUITABILITY FOR A PARTICULAR PURPOSE, OR DESIGN OF SUCH PRODUCT OR PRODUCTS.

IN NO EVENT SHALL GSI BE LIABLE FOR ANY DIRECT, INDIRECT, INCIDENTAL OR CONSEQUENTIAL DAMAGES, INCLUDING, WITHOUT LIMITATION, LOSS OF ANTICIPATED PROFITS OR BENEFITS. PURCHASER'S SOLE AND EXCLUSIVE REMEDY SHALL BE LIMITED TO THAT STATED ABOVE, WHICH SHALL NOT EXCEED THE AMOUNT PAID FOR THE PRODUCT PURCHASED. THIS WARRANTY IS NOT TRANSFERABLE AND APPLIES ONLY TO THE ORIGINAL PURCHASER. GSI SHALL HAVE NO OBLIGATION OR RESPONSIBILITY FOR ANY REPRESENTATIVE OR WARRANTIES MADE BY OR ON BEHALF OF ANY DEALER, AGENT OR DISTRIBUTOR OF GSI.

GSI ASSUMES NO RESPONSIBILITY FOR FIELD MODIFICATIONS OR ERECTION DEFECTS WHICH CREATE STRUCTURAL OR STORAGE QUALITY PROBLEMS. MODIFICATIONS TO THE PRODUCT NOT SPECIFICALLY COVERED BY THE CONTENTS OF THIS MANUAL WILL NULLIFY ANY PRODUCT WARRANTY THAT MIGHT HAVE BEEN OTHERWISE AVAILABLE.

THE FOREGOING WARRANTY SHALL NOT COVER PRODUCTS OR PARTS WHICH HAVE BEEN DAMAGED BY NEGLIGENT USE, MISUSE, ALTERATION OR ACCIDENT. THIS WARRANTY COVERS ONLY PRODUCTS MANUFACTURED BY GSI. THIS WARRANTY IS EXCLUSIVE AND IN LIEU OF ALL OTHER WARRANTIES EXPRESS OR IMPLIED. GSI RESERVES THE RIGHT TO MAKE DESIGN OR SPECIFICATION CHANGES AT ANY TIME.

PRIOR TO INSTALLATION, PURCHASER HAS THE RESPONSIBILITY TO RESEARCH AND COMPLY WITH ALL FEDERAL, STATE AND LOCAL CODES WHICH MAY APPLY TO THE LOCATION AND INSTALLATION.

SAFETY GUIDELINES

This manual contains information that is important for you, the owner/operator, to know and understand. This information relates to protecting **personal safety** and **preventing equipment problems**. It is the responsibility of the owner/operator to inform anyone operating or working in the area of this equipment of these safety guidelines. To help you recognize this information, we use the symbols that are defined below.

Please read the manual and pay attention to these sections. Failure to read this manual and its safety instructions is a misuse of the equipment and may lead to serious injury or death.



This is the safety alert symbol. It is used to alert you to potential personal injury hazards. Obey all safety messages that follow this symbol to avoid possible injury or death.

 **DANGER**

DANGER indicates an imminently hazardous situation which, if not avoided, will result in death or serious injury.

 **WARNING**

WARNING indicates a potentially hazardous situation which, if not avoided, could result in death or serious injury.

 **CAUTION**

CAUTION indicates a potentially hazardous situation which, if not avoided, may result in minor or moderate injury.

CAUTION

CAUTION used without the safety alert symbol indicates a potentially hazardous situation which, if not avoided, may result in property damage.

NOTE

NOTE indicates information about the equipment that you should pay special attention to.

ROOF WARNING, OPERATION & SAFETY

ROOF DAMAGE WARNING AND DISCLAIMER

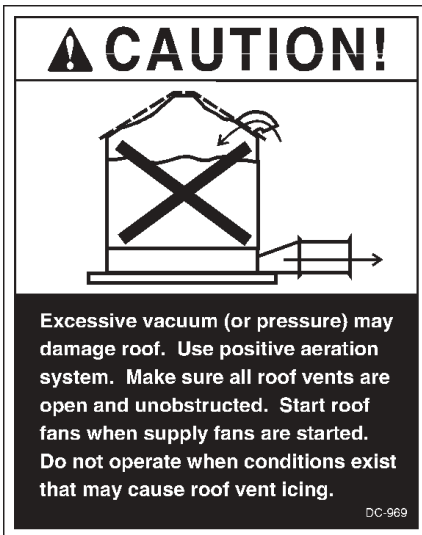

GSI DOES NOT WARRANT ANY ROOF DAMAGE CAUSED BY EXCESSIVE VACUUM OR INTERNAL PRESSURE FROM FANS OR OTHER AIR MOVING SYSTEMS. ADEQUATE VENTILATION AND/OR "MAKEUP AIR" DEVICES SHOULD BE PROVIDED FOR ALL POWERED AIR HANDLING SYSTEMS. GSI DOES NOT RECOMMEND THE USE OF DOWNWARD FLOW SYSTEMS (SUCTION). SEVERE ROOF DAMAGE CAN RESULT FROM ANY BLOCKAGE OF AIR PASSAGES. RUNNING FANS DURING HIGH HUMIDITY/COLD WEATHER CONDITIONS CAN CAUSE AIR EXHAUST OR INTAKE PORTS TO FREEZE.

SUPER SPREAD GRAIN SPREADER OPERATION

Thank you for choosing a GSI/Airstream product. It is designed to give excellent performance and service for many years.

This manual describes the installation and operation of the Grain Spreader. It is designed to spread grain and fines evenly throughout the bin.

The principal concern of the GSI Group, Inc. ("GSI") is your safety and the safety of others associated with grain handling equipment. This manual is written to help you understand safe operating procedures, and some of the problems that may be encountered by the operator or other personnel.

As owner and/or operator, it is your responsibility to know what requirements, hazards and precautions exist, and to inform all personnel associated with the equipment, or who are in the area. Avoid any alterations to the equipment. Such alterations may produce a very dangerous situation, where serious injury or death may occur.

SAFETY ALERT SYMBOL

The symbol shown is used to call your attention to instructions concerning your personal safety. Watch for this symbol; it points out important safety precautions. It means "ATTENTION", "WARNING", "CAUTION", and "DANGER". Read the message and be cautious to the possibility of personal injury or death.



WARNING! BE ALERT!

Personnel operating or working around grain handling equipment should read this manual. This manual must be delivered with the equipment to its owner. Failure to read this manual and its safety instructions is a misuse of the equipment.

SAFETY ALERT DECALS

Grain Systems, Inc. recommends contacting your local power company, and having a representative survey your installation so the wiring is compatible with their system, and adequate power is supplied to your unit.

Safety decals should be read and understood by all people in the grain handling area. The bottom right decal should be present on the inside bin door cover of the two ring door, 24" porthole door cover and the roof manway cover.

If a decal is damaged or is missing contact:

Grain Systems, Inc.
1004 E. Illinois St.
Assumption, IL 62510
217-226-4421

A free replacement will be sent to you.

! DANGER



**Disconnect electricity before inspecting or servicing.
Keep guards and screens on exposed areas.**

MAY CAUSE SERIOUS INJURY OR DEATH

DC-4661992 GRAIN SYSTEMS INC.

! DANGER



Do not operate with service door removed.

MAY CAUSE SERIOUS INJURY OR DEATH

DC-4651989 GRAIN SYSTEMS INC

! DANGER



Rotating flighting can kill or dismember.



Flowing material can trap and suffocate.



Crusted material can collapse and suffocate.

**Keep clear of all augers.
DO NOT ENTER this bin!**

If you must enter this bin:

1. Shut off and lock out all power.
2. Use safety harness and safety line.
3. Station another person outside the bin.
4. Avoid the center of the bin.
5. Wear proper breathing equipment or respirator.

Failure to heed these warnings will result in serious injury or death.

DC-552

ASSEMBLY INSTRUCTIONS

HARDWARE LIST FOR SPD-2073 & SPD-2074

Item #	Part #	Quantity	Description
11	SPD-2008	3	Hanger Extention
12	SPD-2010	3	Hanger Bracket
23	S-4276	12	5/16-18 x 1 1/4" N. F. T. Bolt, grade 5
28	S-1147	38	5/16" Lockwasher
29	S-396	34	5/16"-18 Hex Nut
31	S-845	28	5/16" Flatwasher
33	S-6078	2	5/16"-18 x 1/4" Set screw
34	S-6079	1	1/4" x 1" Roll Pin
37	*	1	3/8" Eyebolt
	00405341	1	Danger Decal

Item # refers to parts list on page 10 and assembly drawing on page 11.

The Scattergrain is a direct drive spreader. The unit is powered by a totally enclosed, 1 HP motor. Two types of motors are offered with the super spread. One has a single phase motor (FFD-200-1) and the other model (FFD-200-3) has a three phase motor. Maximum grain capacity is 4,000 to 6,000 bushels per hour, depending on moisture content, weight and fines evenly throughout the bin. This will help prevent uneven drying.

1. Carefully unpack the unit and inspect for shipping damage.
2. Check tightness of all bolts in the cone and blade assemblies.
3. Remove blade extension from blade assembly for 24-foot diameter bins and smaller (Figure 2).

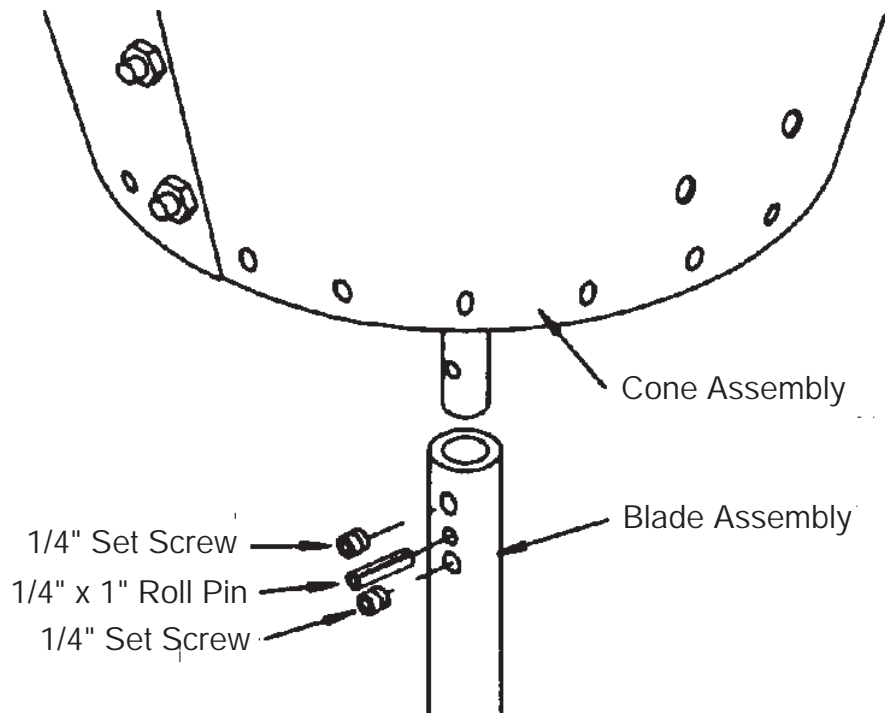
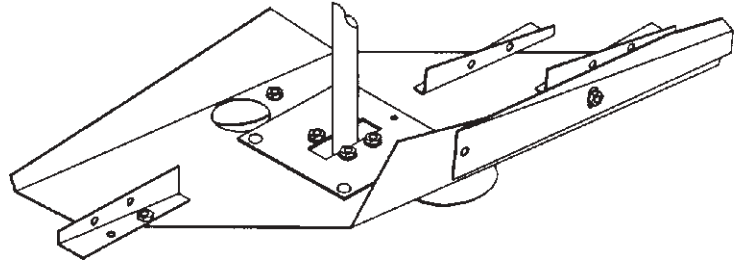

Figure 1: Spreader cone assembly and blade assembly connection.

ASSEMBLY INSTRUCTIONS

6. Turn the three spreader diverters outward (Figure 2). The diverters on the blade assembly are turned inward for shipping purposes. Further adjustments may be required after installation.
7. Use two 5/16"-18 x 1.1/4" bolts, four 5/16" flatwashers, two 5/16" lockwashers, and two 5/16"-18 nuts to fasten each of the three hanger brackets inside the spreader cone (Figure 3). The five mounting slots provided in the hanger brackets are used for adjusting the spreader up and down inside the bin. Location is dependent on several factors such as interference with stirring systems and grain bouncing off spreader motor onto bin roof.
8. Measure bin opening (hatch collar) to select correct slots for bolting hanger extensions to hanger brackets. All GSI bins with standard peak roof cap have a hatch collar diameter 31.1/2". Loosely mount each hanger extension to a hanger bracket, using the appropriate slots with two 5/16"-18 x 1.1/4" bolts, two 5/16" lockwashers, four 5/16" flatwashers, and two 5/16"-18 nuts (Figure 3).
9. Add 3/8" eyebolt to the top of motor.
10. Compare assembled unit with parts assembly drawing (page 11) to make certain that all parts are properly installed.

Note: Remove blade extension (SPD-2002) for 24' & smaller bins



Turn spreader diverters SPD-2003

Figure 2: The diverter segments on the blade.

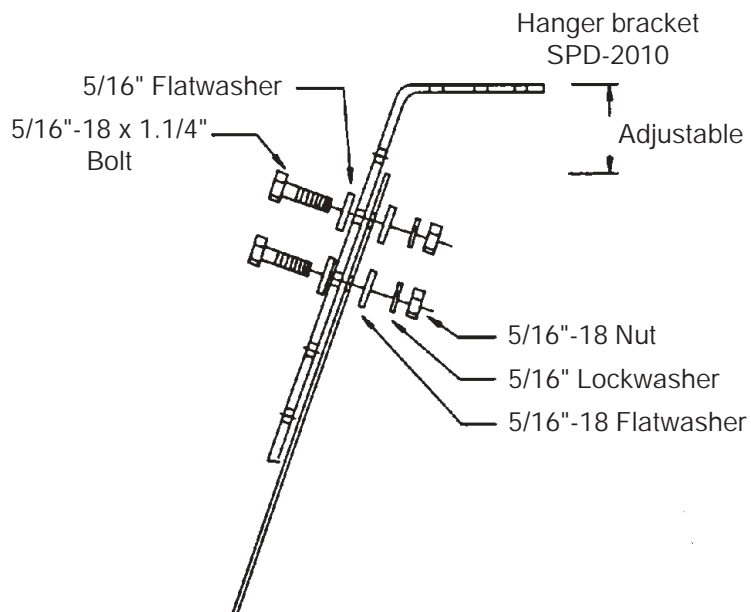

Figure 3: The spreader cone connection to the hanger bracket.

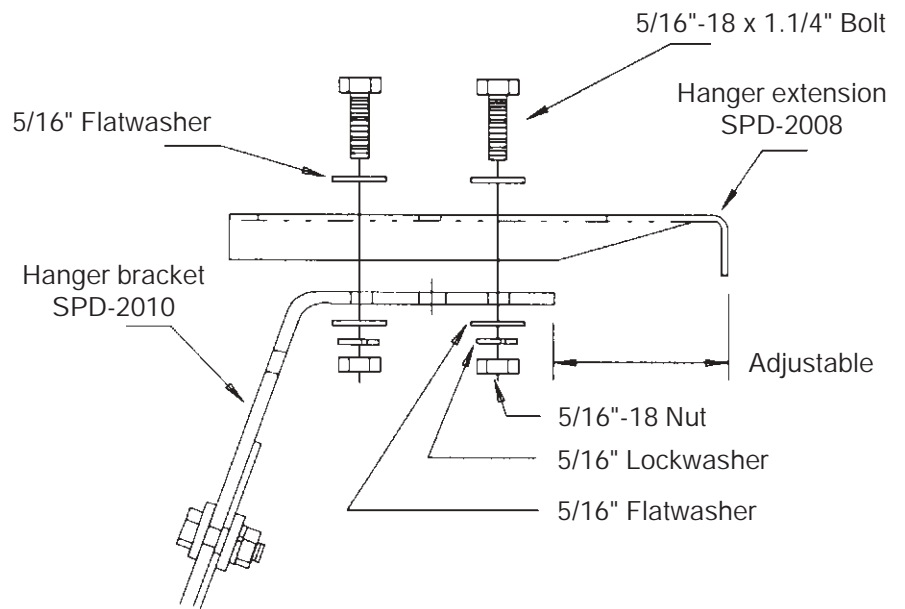

Figure 4: The hanger bracket connection to the hanger extension.

PARTS LIST

FFD-200-1 (1 PH MOTOR) & FFD-200-3 (3 PH MOTOR)

ITEM #	PART #	QUANTITY	DESCRIPTION
1	002-1105-2	1	1 HP 1-Phase C-Face Motor (special)
2	002-1088-0	1	1 HP 3-Phase C-Face Motor (special)
3	017-1534-1	1	Pinion Gear
4	SPD-2154	1	MI Gear Box With 56C Adapter (069-1304-0)
5	TFC-0054	1	3/4" Seal-Tite Elbow-CSA
6	FH-6563	1	3/4" Seal-Tite CSA Approved
7	SPD-2151	1	3/4" 45 DEG Seal-Tite Fitting
8	SPD-2068	1	Capacitor Box
9	SPD-2069	1	Capacitor Box Lid
10	SPD-2070	1	Capacitor Clip
11	SPD-2008	3	Hanger Extension
12	SPD-2149	3	Hanger Bracket
13	SPD-2062	2	Gear Box Mounting Bracket
14	SPD-2061	1	Spreader Cone
15	SPD-2004	1	Upper Back-up Plate
16	SPD-2063	1	Spreader Blade
17	SPD-2003	3	Spreader Diverter
18	SPD-2005	1	Lower Back-up Plate
19	SPD-2171	1	Drive Shaft Weldment
20	SPD-2006	2	Damper
21	SPD-2064	1	Blade Extension
22	*	1	Set Screw
23	S-277	12	5/16"-18 x 1.1/4" Hex Capscrew, grade 5
24	SPD-2109	*	Special Gearbox Lubricant
25	S-1054	4	3/8" Lockwasher
26	S-456	4	3/8"-16 Hex Nut
27	S-6606	15	5/16" x 3/4" Hex HD Bolt (serrated)
29	S-3611	34	5/16"-18 Hex Nut
30	S-6076	6	5/16"-18 x 3/4" Carriage Bolt
31	S-845	6	5/16" Flatwasher
32	S-6606	5	5/16"-18 x 3/4" Hex HD Bolt (serrated)
33	S-6078	2	5/16"-18 x 1/4" Set Screw
34	S-6079	1	1/4" x 1" Roll Pin
35	S-6077	2	U-Bolt 3/8"-16 x 1"W x 2.1/4" Lg.
36	S-7621	4	10-32 x 3/4" Self Tap Screw
37	*	1	3/8" Eyebolt
	SPD-2108		1 HP Spreader Blade Replacement Kit
	TFH-2104	1	EC1216C06 Capacitor (1 Phase)
	FH-7001	1	OC3020F12 Capacitor (1 Phase)

*Denotes items included in gear box assembly.
 All parts are standard except for items 1, 2, 10, 36 & 41.
 (See description for applications).

PARTS ASSEMBLY



WARNING!
Automatic Reset
Overload Protection

NOTE: Tighten set
screws against flat on
motor shaft

Special Gearbox
Lubricant

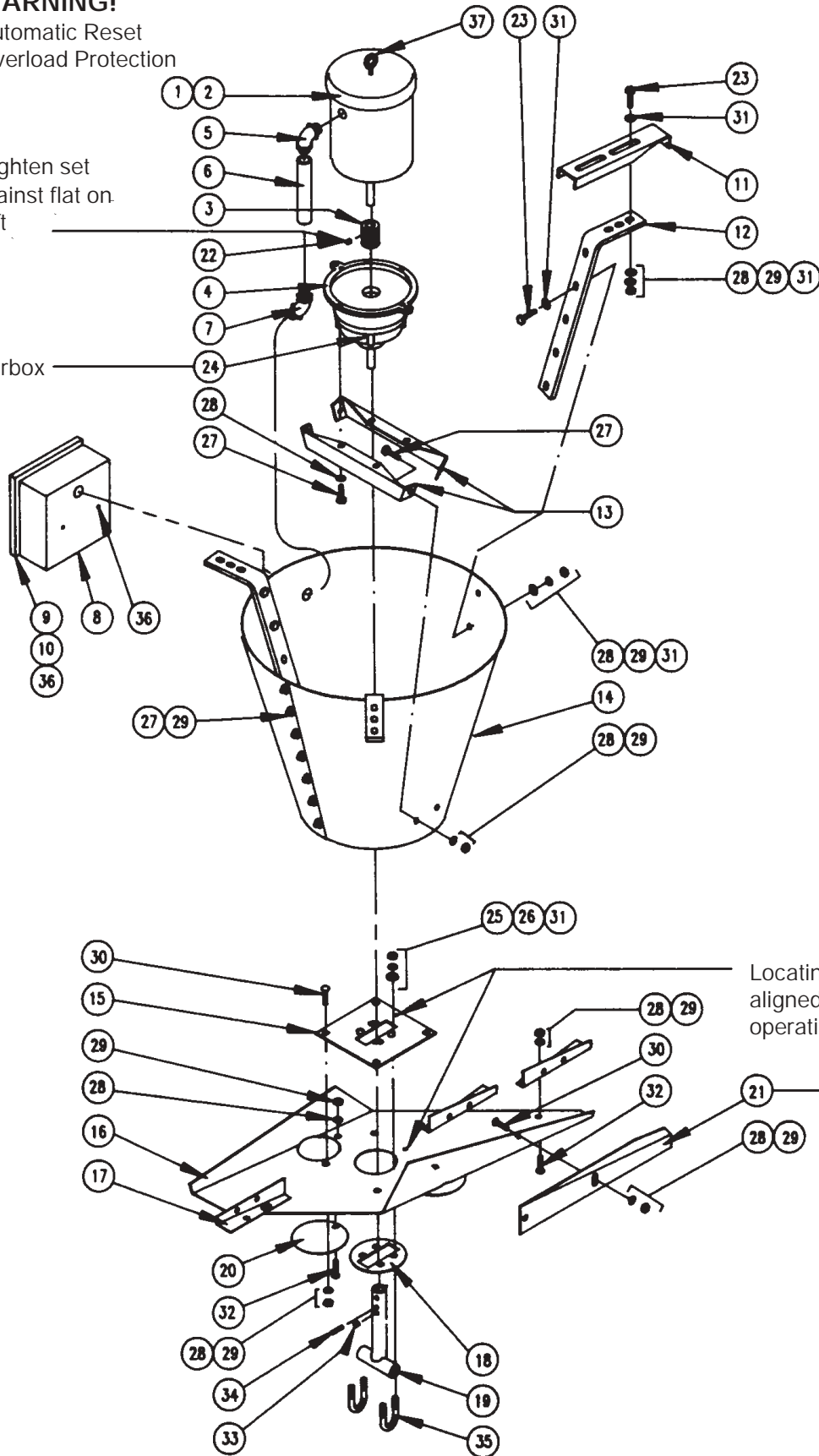

Locating holes must be
aligned for proper
operation

Not required for
smaller bins

INSTALLATION

The units are shipped with the motor wires disconnected. Carefully connect motor wires for desired operating voltage as indicated on the wiring diagram on page 13. Model SPD-2073 will be wired for 230V. The other models will not. Be certain to use electrical connectors of adequate size. The table below provides wire size information.

The 1 HP motor is protected with an internal automatic reset overload. However, it is advisable to provide additional protection with fuse or circuit breaker.

The motor should turn the spreader blade counterclockwise as viewed from above the unit. If the three phase unit turns clockwise, the rotation can be changed.

This may be done by interchanging any two of the three power wire connections. The rotation cannot be reversed on single phase unit.

Make sure eyebolt is securely fastened to motor before installing spreader. **DO NOT STAND UNDER-NEATH UNIT WHILE IT IS LIFTED INTO PLACE.**

	1 HP Spreader Motor				
	1750 RPM				
	1 Phase		3 Phase		
	110V	230V	208V	230V	460V
Full Load Amps	9.4	4.7	3	2.8	1.4
Minimum Wire Size					
Copper Wire					
50' Run	14	14	14	14	14
100' Run	12	14	14	14	14
150' Run	10	14	14	14	14
200' Run	8	14	14	14	14
Aluminum Wire					
50' Run	12	12	12	12	12
100' Run	10	12	12	12	12
150' Run	8	12	12	12	12
200' Run	6	12	12	12	12
Fuse Size (Slow Blow)	20	15	10	10	5
Breaker Size	25	20	15	15	10

INSTALLATION

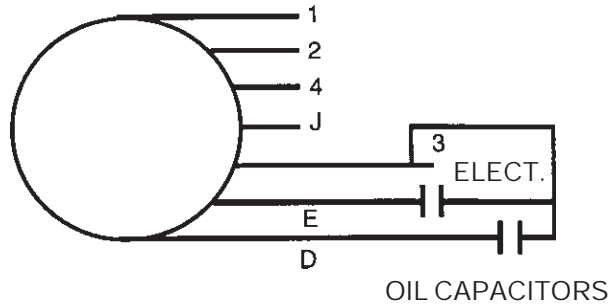

SINGLE PHASE-DUAL VOLTAGE WIRING DIAGRAM

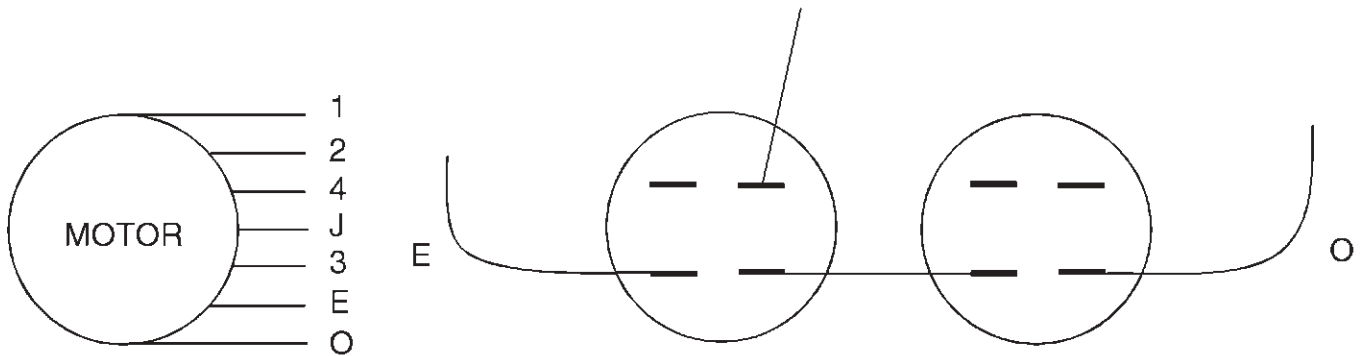
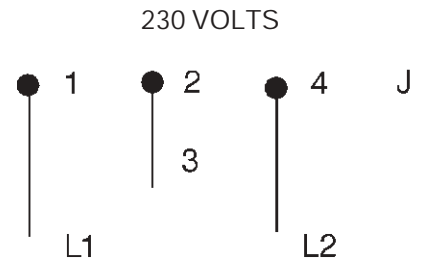
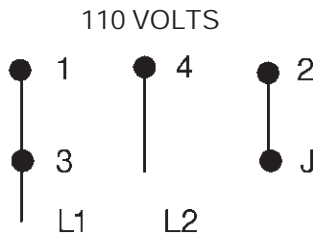

- For 110 volts 1, 3 and the extra wire on the capacitor go to L1.
- 4 goes to L2, and 2 and J tie together.
- E from the motor goes to E on the capacitor.
- O from the motor goes to O on the capacitor.

- For 230 volts 1 goes to L1.
- 2 and 3 and the extra wire on the capacitor go together.
- 4 goes to L2.
- J is tied off by itself.
- E from the motor goes to E on the capacitor.
- O from the motor goes to O on the capacitor.

THREE PHASE-DUAL VOLTAGE WIRING DIAGRAM

208/230 VOLTS

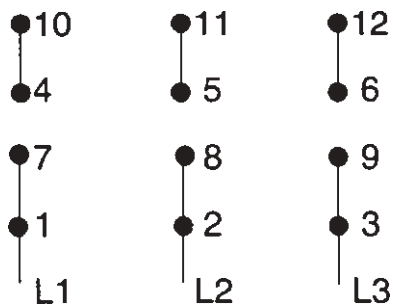

460 VOLTS

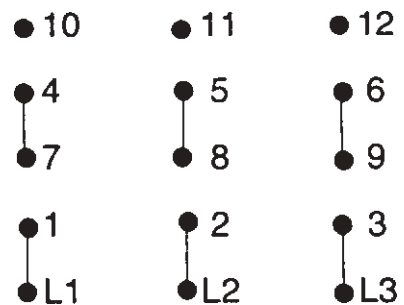

INSTALLATION

1. Adjust hanger extensions to fit roof opening and install the power spread unit.
2. Use the 9/32" hole at the end of each hanger extension and bolt hanger extensions to hatch collar.
3. Then tighten all bolts holding hanger extensions.
4. Once unit is installed, use a carpenter's level across the top of the spreader cone to make sure it is level in all directions (Figure 5).
5. If required, add spacer washers between hanger brackets and hanger extensions to level unit (Figure 6).



The 1HP motor is protected with an internal automatic reset overload. Before servicing, all power to the unit must be disconnected and locked out to avoid a possible reset/restart and serious injury.

Before connecting and applying power, rotate the spreader blade by hand to be certain it rotates freely without obstruction. The motor turns the spreader blade counterclockwise as viewed from above the unit. The super spread unit requires 115 or 230 volt 1 PH or 230 or 460 volt

3 phase power supply. The minimum wire size is 14 gauge for runs up to 200 feet. It is advisable to provide additional protection such as 15 amp slow blow fuses or 20 amp circuit breaker. Consult a licensed electrician for wire size on longer runs. Regardless of grain type and bin size, the grain flow must be directly down (vertical) and centered (horizontal) within the spreader cone (Figure 7). This has to be done to prevent high and low grain surface areas from one side of the bin to the other.

Mount unit level inside the bin

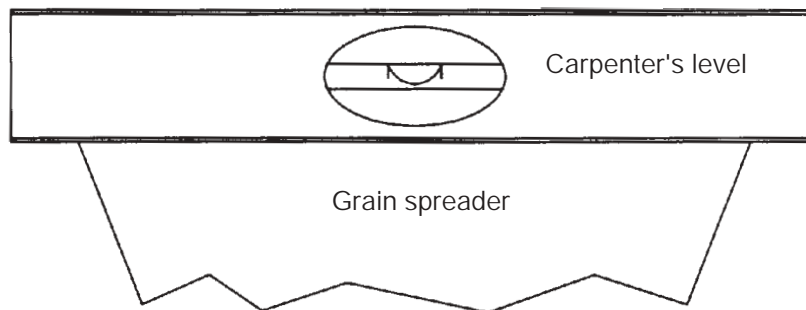

Figure 5: Mount spreader and check with level.

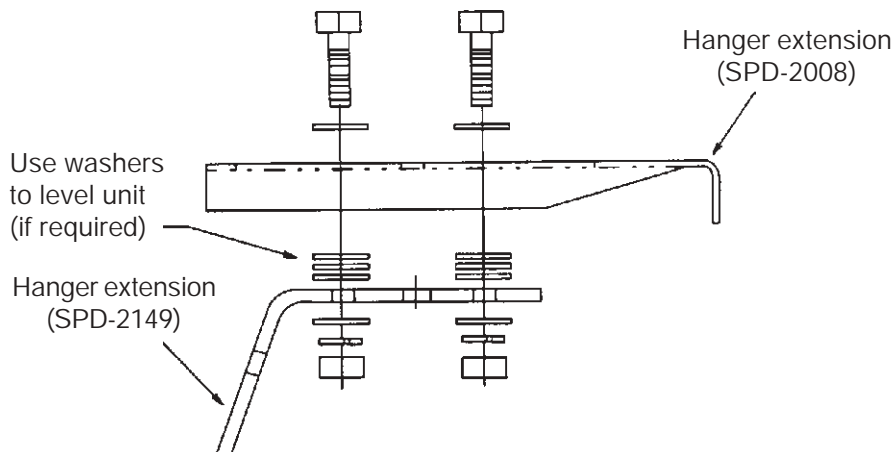

Figure 6: Use washers to level unit.

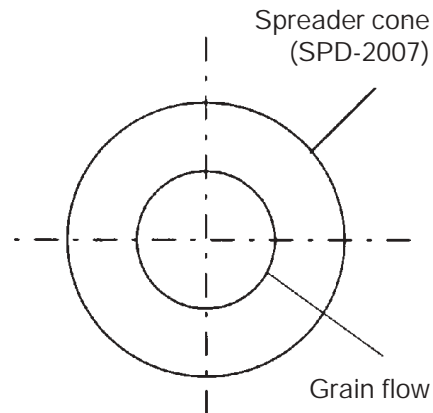
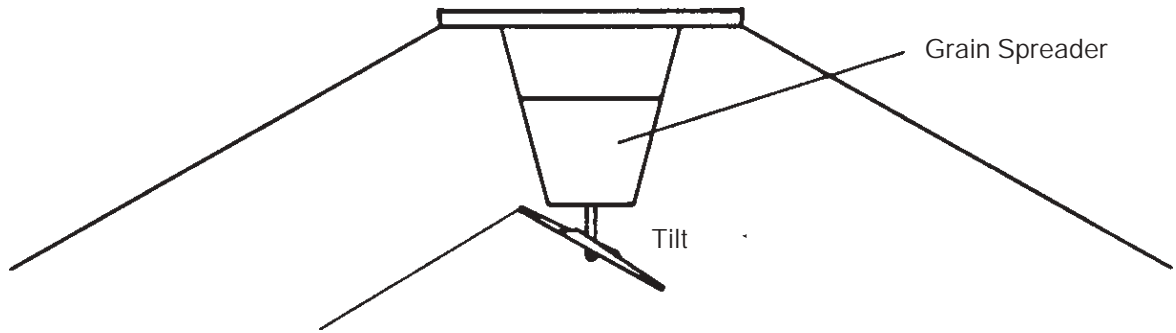

Figure 7: Grain flow must be centered within the spreader cone.

OPERATING INSTRUCTIONS



Single spreader diverter end up for desired grain spread.

Figure 8: Adjustment of the tilt.

The grain spreader blade assembly has four features for adjusting grain flow pattern.

1. Tilt is the adjustment of the entire spreader blade, which controls overall grain spreading. Tilt is adjusted by loosening the two U-bolts that allow the tipping of

the blade up and down. This may vary according to bin diameter and fill rate (Figure 8).

2. Spreader diverters are used to increase or decrease grain flow resistance over spreader blade. With the diverters straight (Figure 9) the grain will travel fur-

ther. Angled grain diverters will reduce the throwing distance.

3. Blade extension is used when extra throwing distance is required for larger bins.

4. Dampers are used to control center filling.

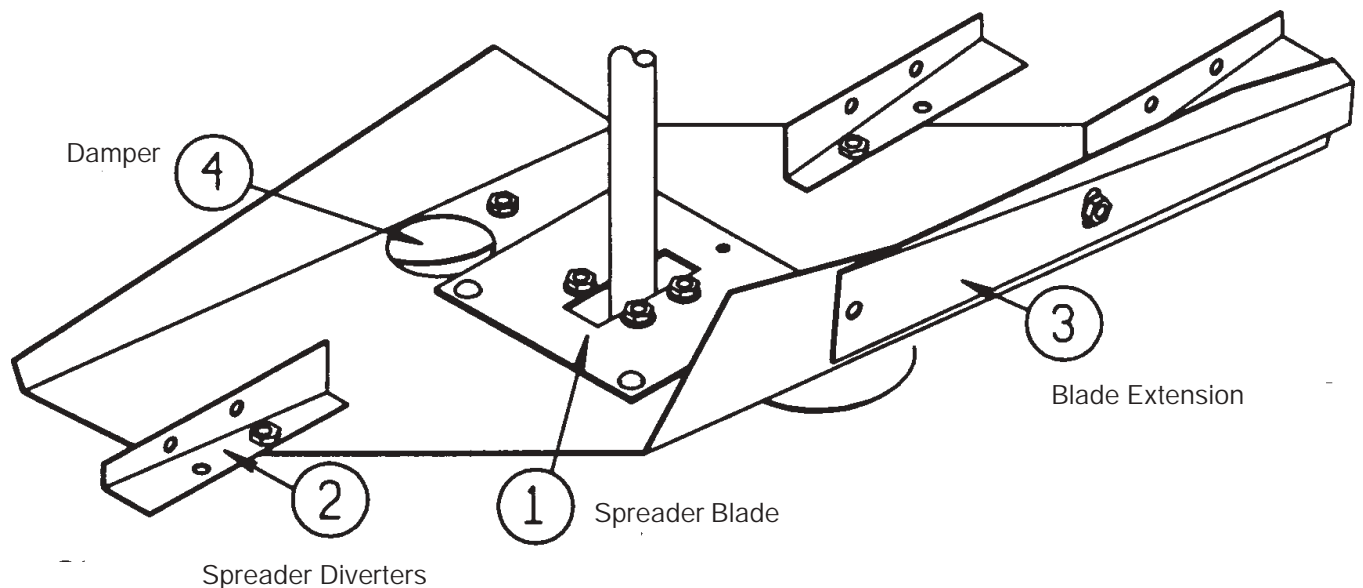

Figure 9: Four features for adjusting the grain flow pattern.

OPERATING INSTRUCTIONS

ADJUSTMENT FOR BIN FILL

			LARGE BIN 36" DIA. AND GREATER	SMALL BIN 24" DIA. AND LESS
REF #	PART	TYPE	OPERATION/PROCEDURE	OPERATION/PROCEDURE
1	Spreader Blade	Tilt	Decrease (flatten)/loosen U-bolts and pivot the blade to horizontal. Always refer to single diverter side as gauge.	Increase/loosen U-bolts and pivot the blade (single diverter side) upward.
2	Spreader Diverter	Single Side	Decrease (center filling)/loosen bolts and rotate diverter clockwise.	Increase (center filling)/loosen bolt and rotate diverter counter-clockwise.
		Dual Side	Decrease (center filling)/loosen bolts and rotate diverters clockwise to direct flow in line with grain stream.	Increase (center filling)/loosen bolt and rotate diverters counterclockwise to direct flow across grain stream.
3	Blade Extension	Tilt	Increase/loosen bolt and pivot the extension upward to maximum allowance in slotted hole.	Remove blade extension.
4	Damper	Opening	Decrease (center filling)/loosen bolts and pivot dampers to nearly closed position.	Increase (center filling)/loosen bolts and pivot dampers to almost fully open position.

Ref # refers to Figure 9 on page 15.

1. Rotation is always viewed from top of the unit looking down onto the blade.
2. Be sure to fully tighten all bolts after each adjustment is made.
3. These adjustments describe the requirements for both extremes of bin sizes. For bin sizes between 24' and 36' in diameter start with intermediate adjustments, then vary slightly as required.

OPERATING INSTRUCTIONS

MAINTENANCE

For normal operation, annually relubricate both motor bearings with approximately ten drops of 5W-30 oil. The gears of the gear box assembly are lubricated with a special high temperature, food grade lubricant (SPD-2109) at the time of manufacturing. The level of grease in the gear box should be checked annually and will normally not require further lubrication unless seal breakage occurs. After the grease has settled to the bottom of the gear box, the grease level can be checked. The grease level should

not be more than 1/4" below the vent plug (Figure 10). It may be necessary to insert a wire through vent plug hole to find the grease level. The level also can be checked by removing motor and viewing grease level through hole for motor pinion gear.

Inspect seals annually for signs of leakage (check bearings annually for tightness).

In the event the motor fails to start, check power supply to the motor. If power supply exists and motor still fails to start, disconnect power and check blade for freedom

of rotation. If power does not exist, check for blown fuse or flipped circuit breaker.

If motor stops operating for no apparent reason, wait approximately five minutes for the automatic overload protection device to reset and reattempt operation. If problem continues, check power supply for voltage and check blade of unit for freedom of rotation.

If motor pinion requires removal for any reason, it must be properly installed and located, as shown in the parts assembly on page 11.

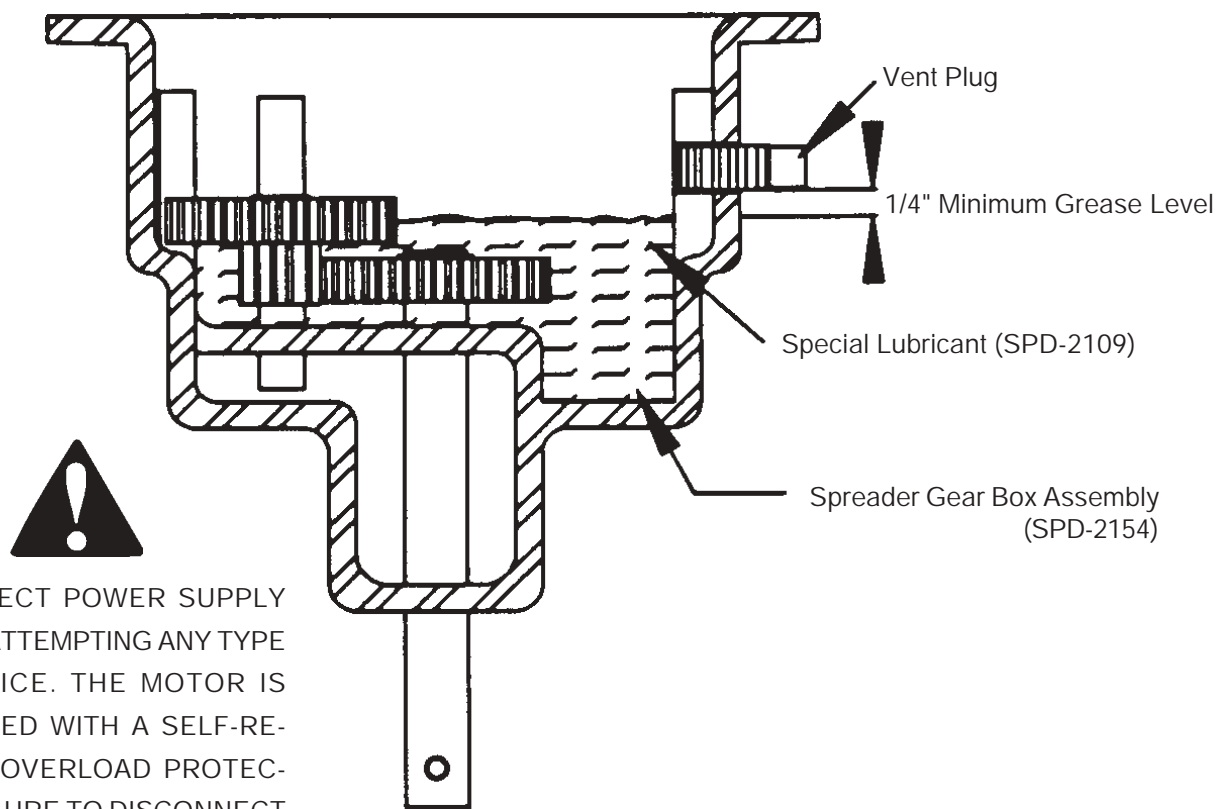

DISCONNECT POWER SUPPLY BEFORE ATTEMPTING ANY TYPE OF SERVICE. THE MOTOR IS PROTECTED WITH A SELF-RESETTING OVERLOAD PROTECTION. FAILURE TO DISCONNECT POWER CAN RESULT IN SERIOUS INJURY OR DEATH.

Figure 10: The gear box assembly showing grease level.

TROUBLESHOOTING GUIDE

CORRECT SPREADING PATTERN

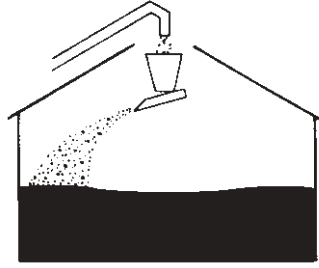

Grain is slightly depressed in the center, grain flow is centered and the spreader is level.

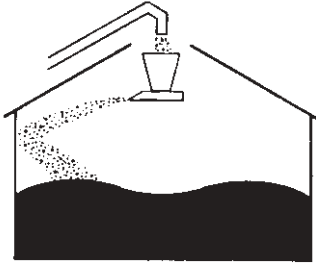
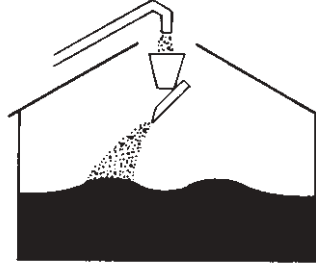
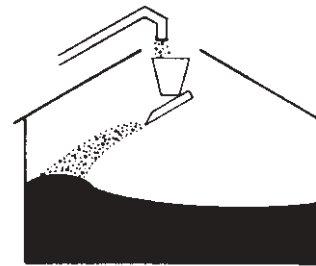
Trouble	Probable Cause	
<p>Large doughnut shaped ring caused by grain hitting high on bin wall.</p>	<p>Tilt blade downward, decrease bite. Remove blade extension.</p>	 <p style="text-align: center;">Spreader blade too flat.</p>
<p>Grain is high in center of bin, small doughnut.</p>	<p>Flatten blade, increase bite, decrease grain flow to spreader. Add blade extension.</p>	 <p style="text-align: center;">Spreader blade too steep.</p>
<p>Grain is high on one side of bin.</p>	<p>Level spreader, correct grain flow to spreader, (never allow grain to flow into spreader at an angle or off center).</p>	 <p style="text-align: center;">Not level, not centered.</p>

GRAIN CONDITIONING SYSTEMS

THE GSI GROUP



1004 E. Illinois St.
Assumption, IL 62510
Phone 217-226-4421
Toll Free Fax 888-741-3004

Rev: June 26, 2003